

≡ AXESS TRADING

TOILET BACKREST



Toilet Back Rest

The Eisegrip® accessible toilet backrest is a premium Australian made product designed to satisfy all the requirements of Australian Standard 1428.1-2009 (Design for Access and Mobility) and the access provisions of the Building Code of Australia 2011.

Each backrest package includes an installation diagram highlighting critical measurements with compliance to AS1428.1-2009.

Successful results will depend on carefully engineered walls, allowing for adequate blocking within the walls for the fitting of toilet backrests and grab rails.



WC back support gets the green light.

Specifications

PART NO.	ORIENTATION	COMPLIANCE
EGR 800	As Shown	AS1428.1-2009 Amdt 1-2010

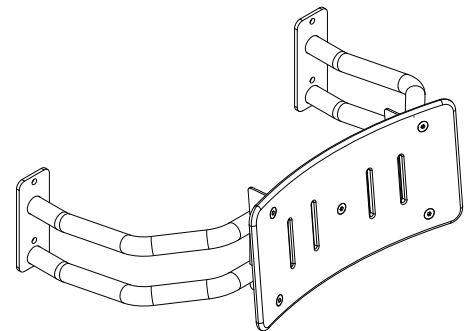

Features

- This accessible design allows disabled people full wheel chair access to the toilet compartment circulation space in accordance with AS1428.1-2009.
- Suitable for Left-hand or Right-hand transfer.
- Backrest moulding is fully washable for long term service.
- The curved shape and solid mounting provides a comfortable and dignified environment for the user.
- Electro polished stainless steel structure for long term service
- Can be used for toilets that have wall mounted cisterns as well as in wall mounted cisterns where grab rails have to be installed behind the toilet pan.
- Each backrest package includes an installation diagram highlighting critical measurements with compliance to AS1428.1-2009.

Toilet Back Rest



Suitable for in wall mounted cisterns

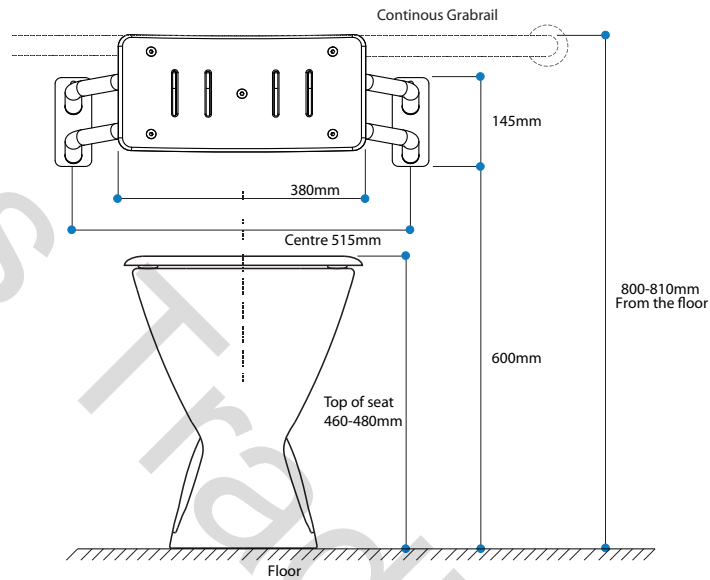

Suitable for wall mounted cisterns

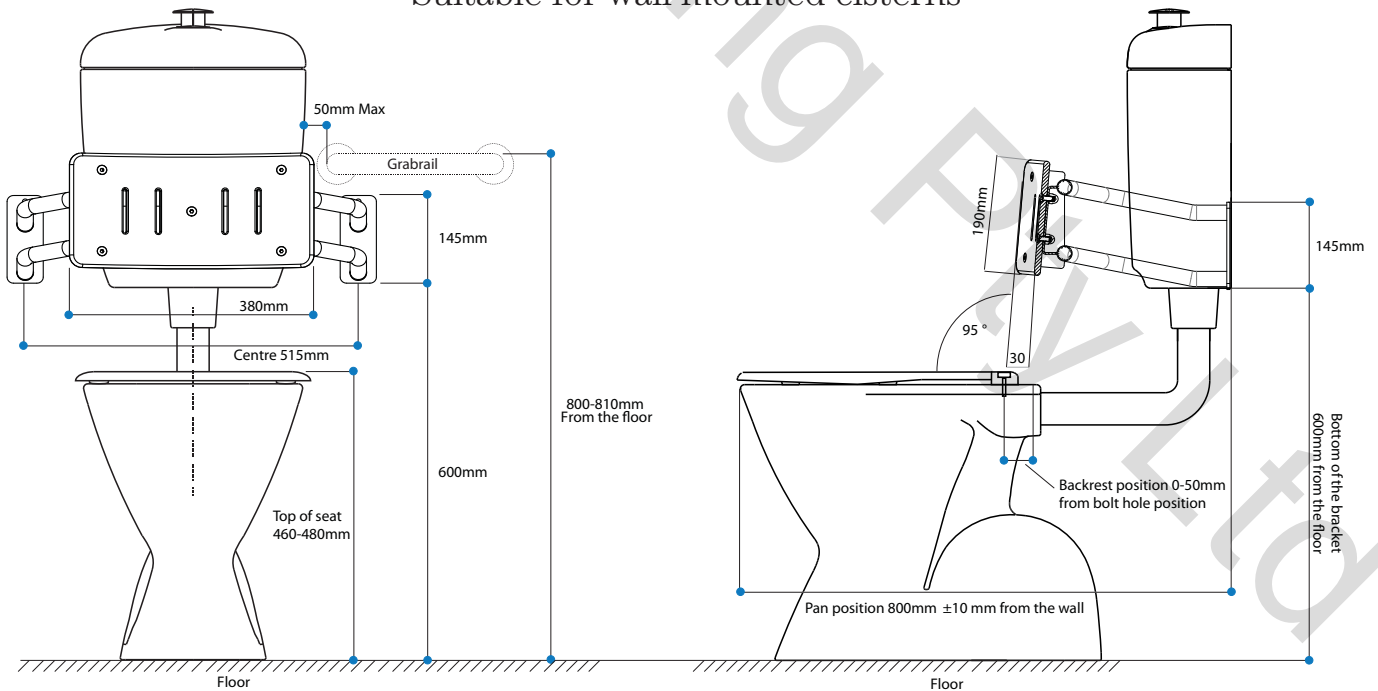

Technical data is available at www.toiletbackrest.com.au

- Engineers report for pull out forces
- Laboratory test report
- REVIT model file for architectural modeling
- Cad drawings

Please phone customer service at 1300 138 086

Toilet Back Rest

Building Code Compliance Guide for EGR800 Backrests.

- It can be a daunting task to understand the the building code and the AS 1428.1-2009. pertinent to accessible facilities.
- The width of the toilet cistern determines the length of the adjacent grabrail and this is often misunderstood , it is therefore that we recommend to use of a CS32450 grabrail for compliance.
- Please see the grabrail installation guide below and note that the measurements do not indicate the position of the fixing flanges but rather the edge of the grab rail itself and it is therefore important to follow the guide for a successful installation.

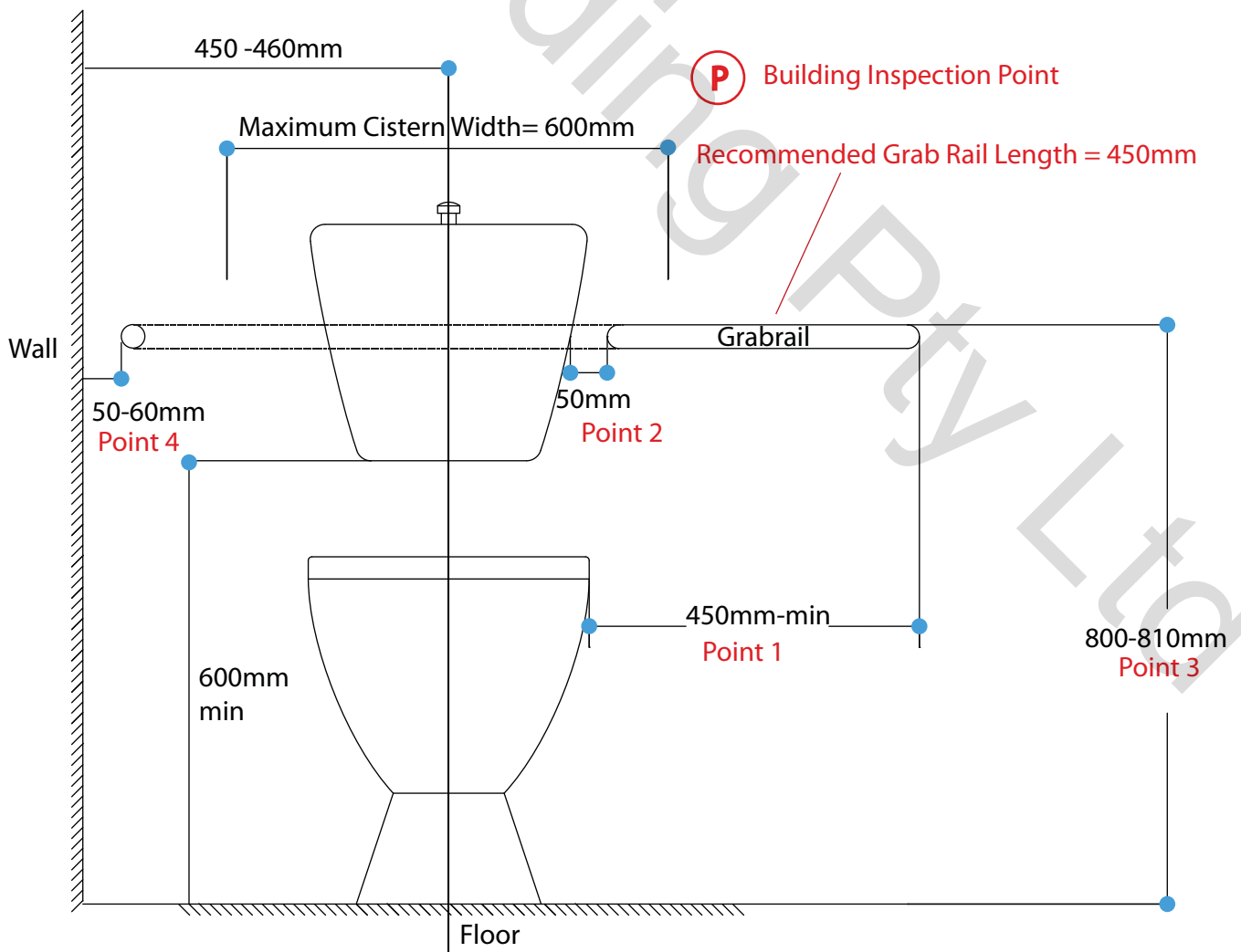

Toilet Back Rest



Suitable for general use.

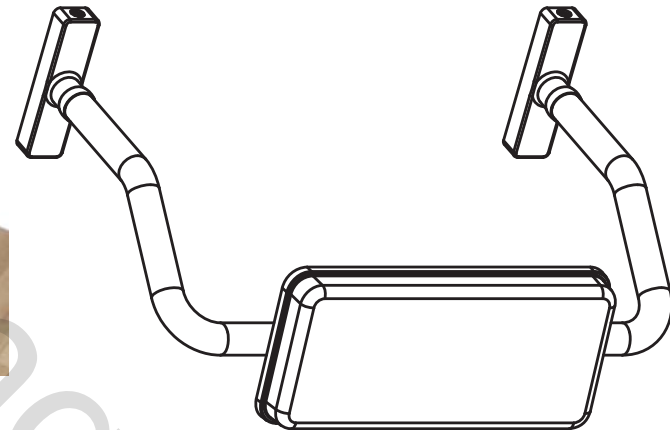

Specifications

<u>PART NO.</u>	<u>ORIENTATION</u>	<u>COMPLIANCE</u>
EGR 750.S	As Shown	AS1428.1-2009 Amdt 1-2010
EGR 750	Without Side Rail	AS1428.1-2009 Amdt 1-2010

Features

- This accessible design allows disabled people full wheel chair access to the toilet compartment circulation space in accordance with AS1428.1-2009.
- Suitable for Left-hand or Right-hand transfer.
- Backrest cushion is fully washable .
- Can be used for toilets that have wall mounted cisterns as well as in wall mounted cisterns where grab rails have to be installed behind the toilet pan.
- Each backrest package includes an installation diagram highlighting critical measurements with compliance to AS1428.1-2009.

Toilet Back Rest

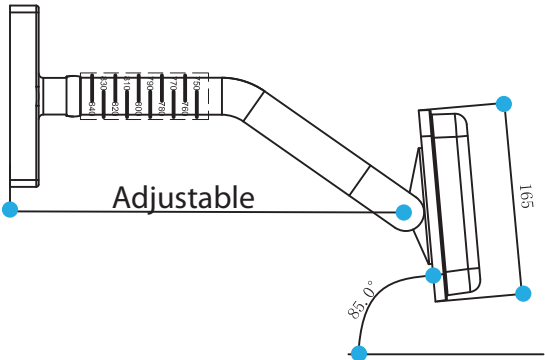
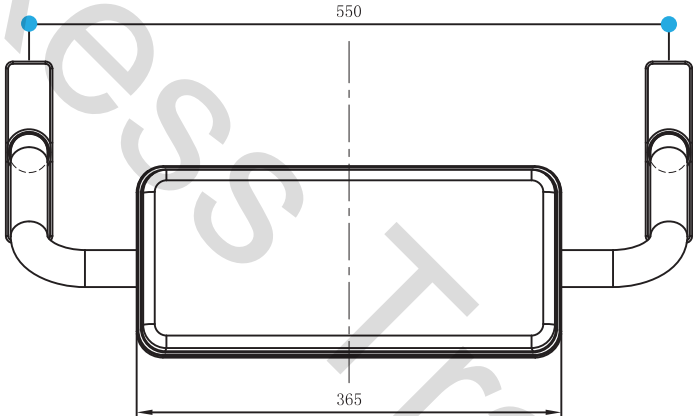

Suitable for general use.

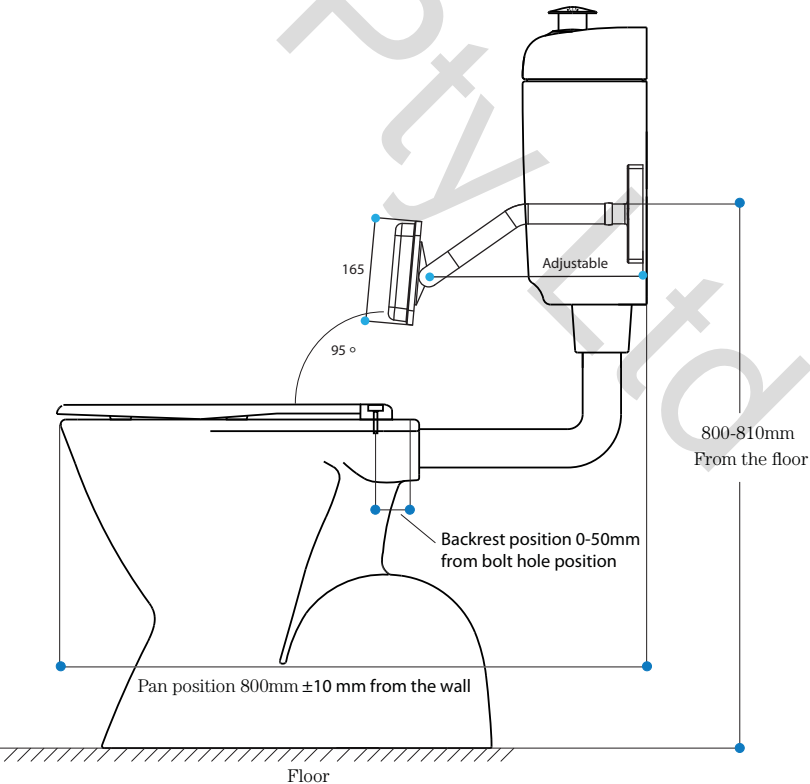
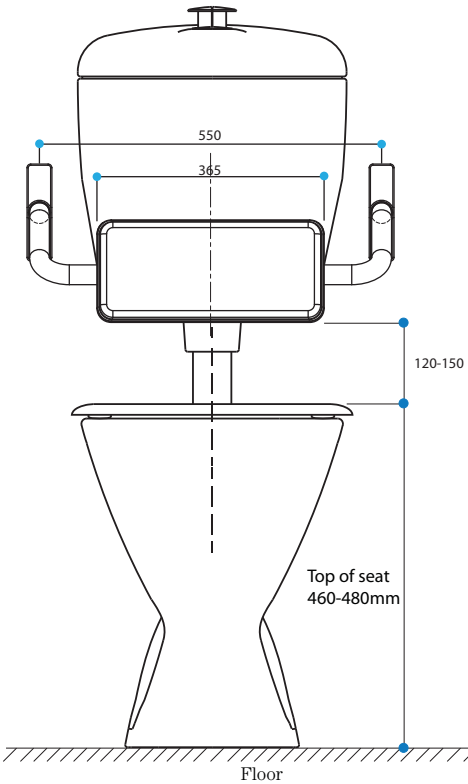

Contact Eisegrip Customer Service

New South Wales
Phone: 1300 720 672

Victoria
Phone: 1300 138 086
Fax: 1300 138 865

www.eisegrip.com.au

